

DB-3P616CP

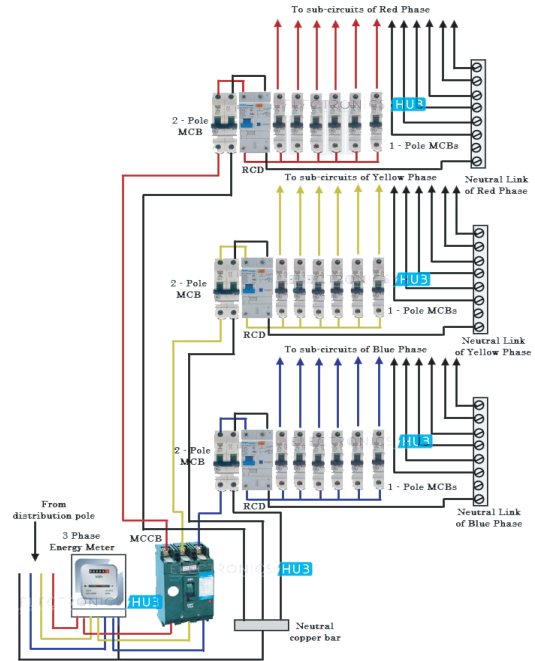

Three Phase Control Panel

Specially made for training & demonstration

DESCRIPTION:

- Phase Indicator: 220V AC, 12mA
- Voltmeter: 0 ~ 500V AC Analog
- Ammeter: 0 ~ 100A Analog
- Frequency Meter: 0 ~ 70Hz Analog
- MCCB: 50A, 400V
- ELCB: 50A, 400V
- Reverse and forward circuit: 20A, 400V
- DOL starter: 50A, 400V
- Star-Delta starter: 50A, 400V
- Door lock system: Manual key type
- Fire alarm system: Two smoke detectors with individual detection system which can indicate the location of fire.